

RABBIT



FEATURES

- Ergonomic DUOREST® System
- Depth and Height Adjustable Backrest
- Optional Mesh Seat
- Optional DUALINDER® Locking System
- Optional 2-step Block footrest

SPECIFICATIONS

- Net Weight : 10.4kg (22.9 lbs)
- Backrest Frame : PP
- Cushion Seats : Polyurethane fill
- Seat Pan Frame : PP
- Fixed Armrest : TPE
- Base Materials : PA6
- Casters Materials : PA6 and PU
- Carton Box Size : 640*440*660 (mm)
- Container Loading Plan : 20ft : 153 boxes
// 40ft : 324 boxes // 40H : 360 boxes

Syn. Leather



Marine Blue
(2SEB2)



Caramel Brown
(2CBN1)



Bubble Grey
(2SEY1)

Mesh (Seat)

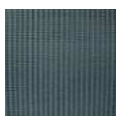

Ash Mesh Grey
(7AMG1)

STATEMENT OF LINE



Standard
(RA-070LDF)



Without Footrest
(RA-070LD)



Without DUALINDER
(RA-070LF)



Mesh Seat
(RA-070M)

DIMENSIONS

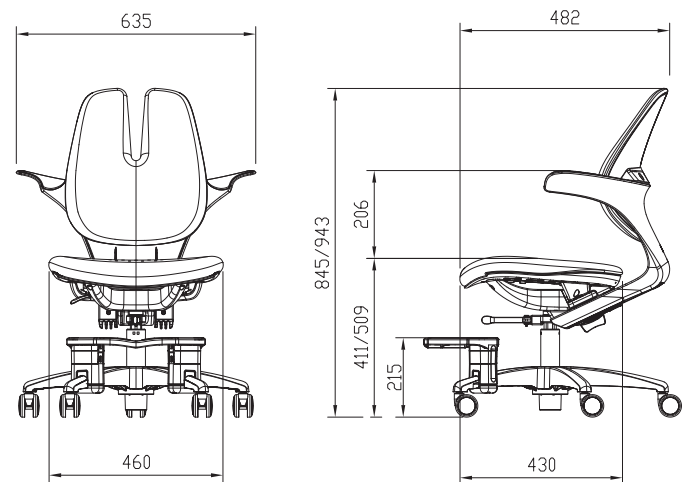

CERTIFICATIONS

TB117-2013
GREENGUARD Gold
ISO 14001 & 9001



DUOBACK CO.,LTD

HQ (Factory) : 27, Gajaeul-ro 32beongil, Seo-gu, Incheon, 22829, Korea.
Sales Office : #1002, 41, Digital-ro 31gil, Guro-gu, Seoul, 08375, Korea
T : +82-2-6204-2584 / F : +82-32-816-4817 / export@duoback.co.kr
www.DUOREST.com