

**Q L6**



**DUOREST®**

**Tablet**

Optional Rotating tablet provides a comfortable seating and study environment

**Seat Pad**

Provides a comfortable sit in any environment.  
\*Thickness : 15mm(0.6")

**Single-piece shell**

Provides a natural cradle.

**Casters**

Soft dual-wheel casters are 60mm O.D. for use on hard floors. Only available in Black and two-tone White.

**Nesting Mechanism**

Allows chairs to be nested together and maximized for space saving.

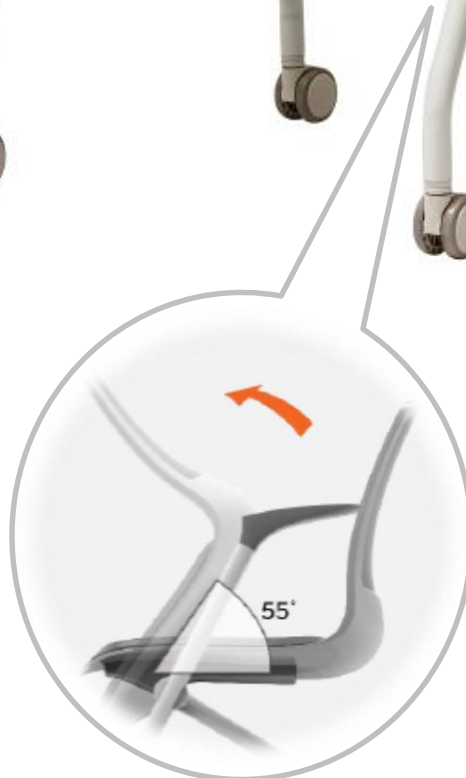

## FEATURES

- Multi-purpose Nesting chair
- Perfect for collaborative, meeting, conference and break space rooms or cafeterias
- Single-piece shell provides a natural cradle
- Nesting Mechanism allows chairs to be nested together
- Seat Pad
- 60mm Hoodless Hard Floor Casters in Black and two-tone White
- Frame available in Black and White

## COLORS

### Black Frame



EK34-J02  
(Black)



EK34-N05  
(Green)



EK34-R04  
(Red)

### White Frame



EK34-G03  
(Light Gray)



EK34-N05  
(Green)



EK34-R04  
(Red)

## STATEMENT OF LINE



QL61N  
Nesting



QL6W1A  
Armless



QL61L  
4Leg



QL6W1S  
Swivel



QL61W  
Wooden Leg



QL6W1T2F  
Tablet

## CERTIFICATIONS

TB117-2013  
ISO 14001 & 9001



## SPECIFICATIONS

• Net Weight	9.7kg (13.56 kg including carton)
• Tablet (Optional)	ABS
• Cushion Seats	Polyurethane fill (15T)
• Seat Pan Frame	PP+GF20%
• Shell Bracket	PA6+GF30%
• Frame	STEEL
• Casters Materials	PA6 +PE
• Carton Box Size	635*600*770(mm)
• Container Loading Plan	20ft : 81 boxes // 40ft : 180 boxes // 40H : 240 boxes

## DIMENSIONS

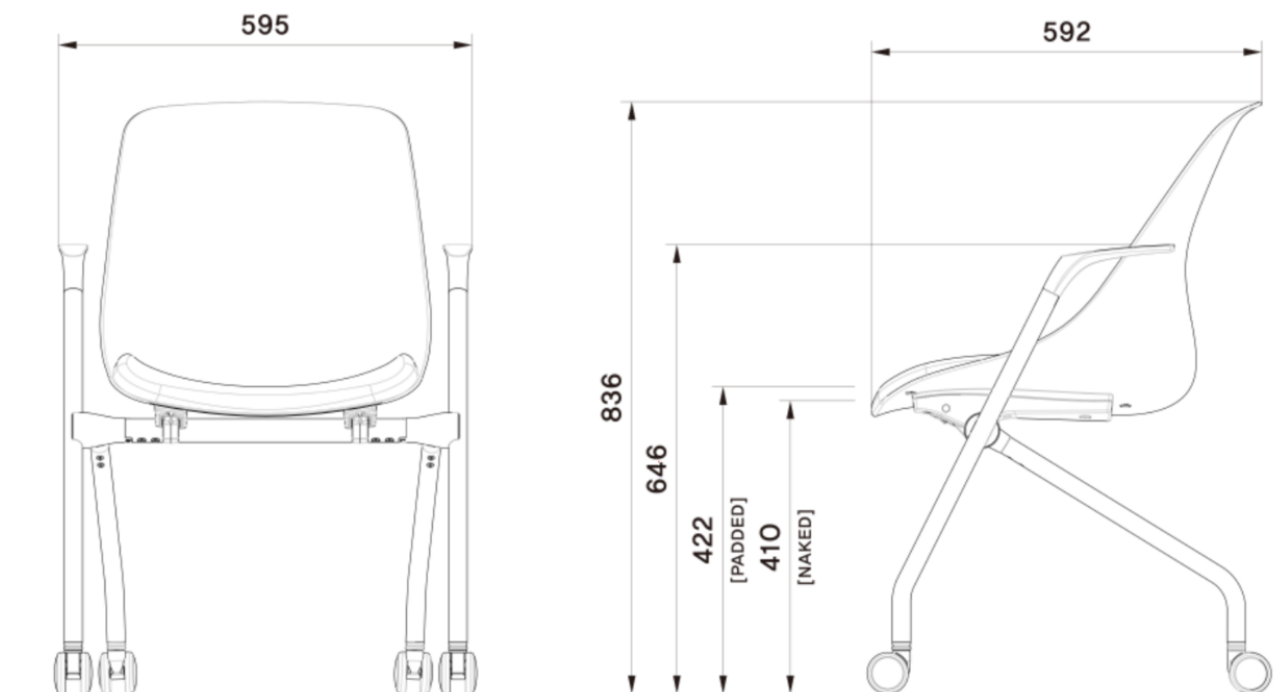

### DUOBACK CO.,LTD

HQ (Factory) : 27, Gajaeul-ro 32beongil, Seo-gu, Incheon, 22829, Korea.  
Sales Office : #1002, 41, Digital-ro 31gil, Guro-gu, Seoul, 08375, Korea  
T : +82-2-6204-2505 / F : +82-32-816-4817 / DUO1350@duoback.co.kr  
www.DUOREST.com

