

# Q2



# STATEMENT OF LINE



**Single-piece shell**  
Provides a natural cradle

Q2\_Sled



Q2\_4leg  
(Standard)

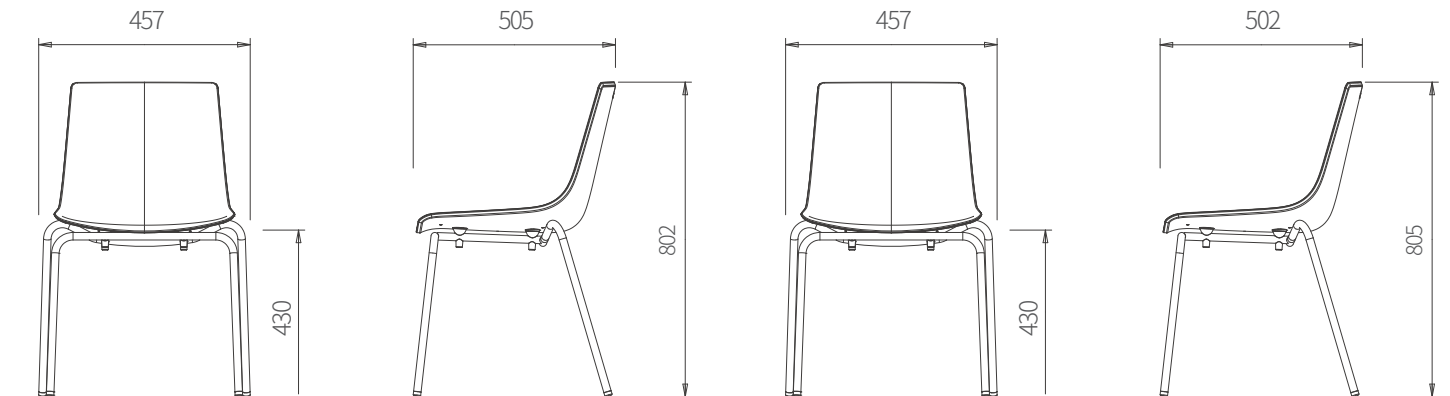

Q2\_Swivel



**Casters**

Soft dual-wheel casters are 65mm O.D. for use on hard floors. Only available in Black.



Q2\_Bar Stool

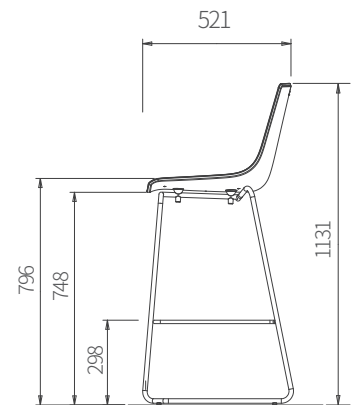
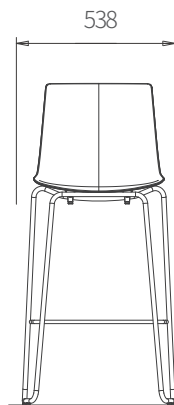
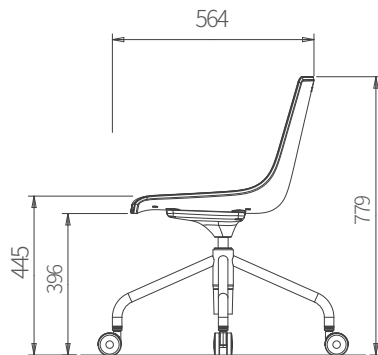
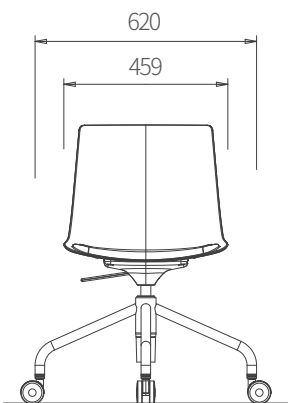

## FEATURES

- Multi-purpose seating including stacking, Bar stool and Swivel models
- Perfect for collaborative, meeting, training and break room spaces
- Single-piece shell Provides a natural cradle
- Optional cushions for seat(Swivel Only)
- 4-leg models stack 3 high on floor
- 5 plastic colors
- Standard 300 lbs. weight capacity
- GREENGUARD GOLD certified

## SPECIFICATIONS

- Net Weight (4leg) : 5.1kg (11.2 lbs)
- Net Weight (sled) : 5.3kg (11.8 lbs)
- Net Weight (bar) : 6.9kg (15.2 lbs)
- Net Weight (swivel) : 7.7kg (17 lbs)
- Shell : PP
- Frame : Steel Ø15.9
- Glide : PA6
- Seat Pan Frame : PP and PU
- Base Materials : Steel
- Casters Materials : PA6 and PU

## PACKAGING (based on Standard Model)

- 2pcs packed in 1 box
- Carton Box Size (mm) : 550\*570\*480
- MOQ : 20ft container
- Container Loading Plan
  - 20ft : 176 boxes (352 chairs)
  - 40ft : 368 boxes (736 chairs)
  - 40H : 420 boxes (840 chairs)

## SHELL COLORS



Q2 Black  
(9QBK9)



Q2 Blue  
(9QBE9)



Q2 Red  
(9QRD9)



Q2 Grey  
(9QGY9)

## FRAME COLORS



Metallic Silver  
(9QMS9)

## CERTIFICATIONS

- ANSI/BIFMA X5.1-2017
- TB117-2013
- GREENGUARD Gold
- ISO 14001 & 9001



### DUOBACK CO.,LTD

HQ (Factory) : 27, Gajaeul-ro 32beongil, Seo-gu, Incheon, 22829, Korea.  
Sales Office : #1002, 41, Digital-ro 31gil, Guro-gu, Seoul, 08375, Korea  
T : +82-2-6204-2584 / F : +82-32-816-4817 / export@duoback.co.kr  
www.DUOREST.com